

# SRF-DR2000

## SERVICE MANUAL

*French Model*

Ver 1.0 1998.03

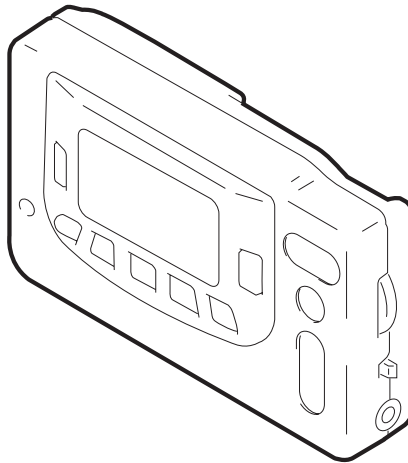

### SPECIFICATIONS

Frequency range	87.5 – 108MHz
FM multiplex	DARC type 64 x 132 FSTN LCD display
Output	⌀ jack (stereo minijack)
Power output	8 mW + 8 mW (at 10% harmonic distortion)
Power requirements	DC 3V, two R6 (size AA) /LR6 batteries
Auto power off function	Approx. 120 minutes
Dimensions	116 x 70.5 x 28 mm (w/h/d) (Approx. 4 5/8 x 2 7/8 x 1 1/8 inches) not incl. projecting parts and controls
Mass	Approx. 150 g (5.3 oz) incl. batteries
Supplied Accessories	Stereo headphones (1)

Design and specifications are subject to change without notice.

**FM DATA RECEIVER**

**SONY®**



## TABLE OF CONTENTS

Specifications .....	1
<b>1. GENERAL</b> .....	2
<b>2. DISASSEMBLY</b>	
2-1. Cabinet (Rear) Removal .....	6
2-2. Main Board Removal .....	6
2-3. MICOM Board, LCD1 Removal .....	7
<b>3. ELECTRICAL ADJUSTMENTS</b> .....	8
<b>4. DIAGRAMS</b>	
4-1. Explanation of IC Terminals .....	9
4-2. Block Diagrams .....	13
4-3. Printed Wiring Boards (Main Section) .....	15
4-4. Schematic Diagram (Main Section) .....	17
4-5. Printed Wiring Boards (MICOM Section) .....	19
4-6. Schematic Diagram (MICOM Section) .....	21
<b>5. EXPLODED VIEW</b> .....	24
<b>6. ELECTRICAL PARTS LIST</b> .....	25

## SECTION 1 GENERAL

This section is extracted from instruction manual.

### Index to Parts and Controls

Refer to the pages indicated in parentheses for details.

#### Main unit

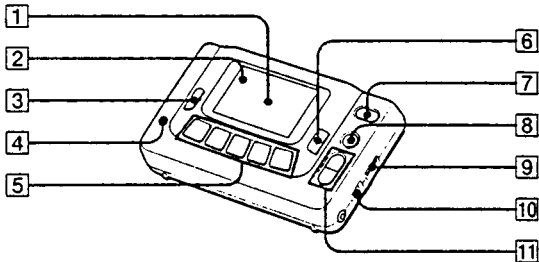

- |  |   |
|--|---|
| <ul style="list-style-type: none"> <li><b>1</b> Display (31)</li> <li><b>2</b> DATA indicator (I) (14)</li> <li><b>3</b> BACK button (15)</li> <li><b>4</b> ENTER button (7, 9)</li> <li><b>5</b> Function buttons (7, 9, 12, 17, 20)</li> </ul> | <ul style="list-style-type: none"> <li><b>6</b> SAVE/MENU button (17, 20)</li> <li><b>7</b> POWER button (7, 9, 12, 20)</li> <li><b>8</b> FM DATA button (12)</li> <li><b>9</b> VOLUME (9)</li> <li><b>10</b> NEWS•MUSIC selector (11)</li> <li><b>11</b> TUNE +/- (9, 10)</li> </ul> |
|--|---|

#### Display

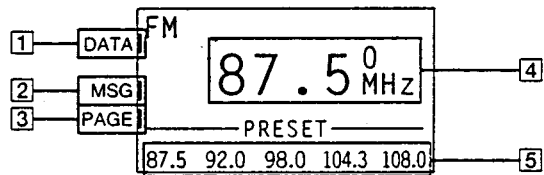

- |  |  |
|--|--|
| <ul style="list-style-type: none"> <li><b>1</b> DATA indicator (I) (14)</li> <li><b>2</b> MSG (Message) indicator (15)</li> <li><b>3</b> PAGE (Paging) indicator (15)</li> </ul> | <ul style="list-style-type: none"> <li><b>4</b> Frequency (10)</li> <li><b>5</b> Preset stations (10)</li> </ul> |
|--|--|

Additional Information

▶Getting Started

**Installing the Batteries**

Open the battery compartment lid and insert two R6 (size AA) batteries (not supplied) with the correct polarity.

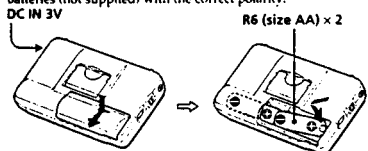

Battery Life	(Approx. hours)	
	Sony Alkaline LR6(SG)	Sony Re(SR)
Audio only	35	14
FM multiplex reception	23	9

\* For maximum performance we recommend that you use alkaline batteries.

**When to Replace the Batteries**

Replace the batteries when "LOW BATTERY" is displayed.

**Notes**

- Insert the batteries with correct polarity.
- The dry batteries cannot be charged.
- Turn off the radio, and then replace the batteries within 20 seconds after the batteries are removed from the battery compartment. Otherwise, the information that has been saved and the preset stations will be erased. In this case, preset the stations again. Be sure to take note of your important data that is saved in the memory.
- When you are not going to use your unit for an extended period of time, remove the batteries to prevent possible damage from battery leakage and corrosion.

5-EN

**To change the selected language**

Press **POWER** to turn off the unit and repeat from step 1.

**Notes**

- The selected language does not translate the FM data. Only the indications in the display will switch over to the selected language, and the FM data will be displayed in the language of that area.
- The three display windows shown below will be displayed in English, even when you set the language other than English.



(see page 7)



(see page 13)

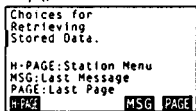

(see page 13)

8-EN

**Listening to a Preset Station**

Once your favorite FM radio stations are preset, simply press the corresponding Function button to recall and tune in to the desired station.

- 1 Press **POWER** to turn on the unit.
- 2 Press the desired Function button which corresponds to the preset station you wish to recall.

**Improving FM radio reception**

Fully extend the headphones cord which functions as an FM antenna.

**To listen with a clearer sound**

When listening to the news, set the **NEWS+MUSIC** selector to **NEWS** for optimum results. Vocal output will be sharper and clearer. When listening to music, set the **NEWS+MUSIC** selector to **MUSIC** for optimum results.



Getting Started

**When the radio turns off unexpectedly**

When you set the Auto Power OFF function to ON, the radio turns off automatically approximately after 120 minutes to prevent unnecessary wear of the batteries. To listen to the radio continuously, press **POWER**. If the radio does not turn on after pressing **POWER**, or if the radio turns off unrelated to the Auto Power OFF feature, the batteries are exhausted.

Replace both batteries with new ones. To set this function see "To set the Auto Power OFF" (page 21) under "Setting the Functions" (page 20).

**Using External Power Sources**

You can connect the following external power sources through the DC IN 3 V jack located on the left side of the unit. (When you plug a cord into the DC IN 3 V jack, the internal batteries are automatically bypassed.)

- House current using a Sony AC-E30HG (not supplied) AC power adaptor
- 12/24 V car battery using a Sony DCC-E230 (not supplied) car battery cord

**Notes**

- When operating the unit with an external power source, do not remove the batteries in the battery compartment which serve as a backup of the memory.
- Use only the recommended AC power adaptor or car battery cord manufactured by Sony. The polarity of the plugs of other manufacturers may be different.



6-EN

▶Operating the Radio

**Manual Tuning**

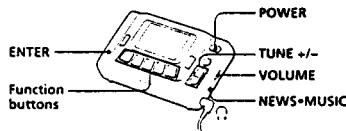

- 1 Connect the stereo headphones to the jack.
- 2 Press **POWER** to turn on the unit.
- 3 Press **TUNE +/-** to manually tune in to the desired station. If you press and hold **TUNE +/-**, the frequency is scanned rapidly. Release the button to stop scanning.
- 4 Adjust the volume with **VOLUME**.

**To turn off the unit**

Press **POWER**.

Operating the Radio

**Selecting a Language**

You can select one of the seven languages (English, French, German, Italian, Spanish, Dutch, Swedish) for the indications in the display. The explanation here is when the language is set in English, and the explanation of the indications in the display will be in English.



- 1 While holding down **ENTER** press **POWER** to turn on the unit. The **LANGUAGE SELECT MENU** appears.



- 2 Press the corresponding Function button to **UP** or **DOWN** to move the cursor to the language you want, and press the Function button corresponding to **ENT**. The indications in the display will switch over to the selected language.

7-EN

**Presetting Stations**

The unit is initially preset with 5 FM radio stations. You can preset up to 5 of your favorite stations.

- 1 Press **POWER** to turn on the unit.
- 2 Press **TUNE +/-** to manually tune in to the desired station.
- 3 Press **ENTER**. When "PRESET" flashes in the display, press one of the Function buttons to preset the station. The beep sounds twice through the headphones and your favorite station is preset to the desired Function button.

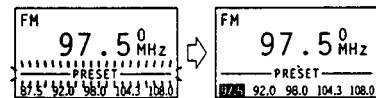

**To change an existing preset station**

Repeat from step 1 and press the desired Function button you wish to change on step 3. The existing preset station of the selected Function button will be erased and replaced with your new favorite station.

10-EN

**Listening to a Preset Station**

Once your favorite FM radio stations are preset, simply press the corresponding Function button to recall and tune in to the desired station.

- 1 Press **POWER** to turn on the unit.
- 2 Press the desired Function button which corresponds to the preset station you wish to recall.

**Improving FM radio reception**

Fully extend the headphones cord which functions as an FM antenna.

**To listen with a clearer sound**

When listening to the news, set the **NEWS+MUSIC** selector to **NEWS** for optimum results. Vocal output will be sharper and clearer. When listening to music, set the **NEWS+MUSIC** selector to **MUSIC** for optimum results.



Operating the Radio

▶Seeing FM Data

**Seeing the Information on Your Receiver**

You can receive up-to-date information that you can read on the display while receiving the FM radio broadcast through FM multiplex reception which is transmitted by a specific FM broadcasting station only. Also, you can choose from 7 languages (English, French, German, Italian, Spanish, Dutch, Swedish) for the indications in the display. (see page 7 "Selecting a Language")

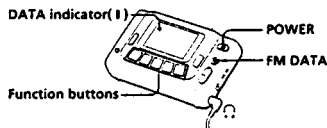

- 1 Connect the stereo headphones to the jack. Since the headphones cord serves as an FM wire antenna, be sure to connect the headphones even when reading the FM data broadcast.
- 2 Press **POWER** to turn on the unit.
- 3 Tune in to a FM multiplex broadcasting station.



\* The menus may differ depending on the participating radio stations in your area.

- 5 Press the corresponding Function button to **M2**. Then, the selecting window for the information you want to see appears.

H-PAGE: FM Multiplex Broadcast  
MSG: Urgent Message  
PAGE: Paging Message

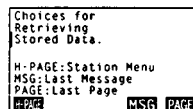

Getting Started

Seeing FM Data

11-EN

12-EN

13-EN

## To See the FM data Broadcast

- 1 Press the corresponding Function button to H-PAGE.
- 2 Select the desired menu by pressing the corresponding Function button to receive further information where applicable.

### DATA indicator

Appearance of the DATA indicator(I) shows you the availability of FM multiplex reception.



#### Indicator is on

The station you tune in to is transmitting FM multiplex information and the reception is strong.

#### Indicator is off

The station you tune in to does not transmit FM multiplex information or the reception is weak.

## When receiving FM multiplex broadcast

Depending on the reception, the audio is received but the data may not be received for FM Data broadcast. Inside buildings or underground areas, the data may not be received or the reception may be poor, and receiving the FM data fully may take a while. Since the headphones cord serves as an FM wire antenna, fully extend the headphones cord.

14-EN

## When receiving urgent Information

When an urgent information is broadcasted while receiving FM Data Broadcast, you will hear a beeping sound through the headphones and the FM Data Broadcast display will automatically switch over to the urgent information. When you receive the urgent information the DATA and MSG indications appear at the left side of the display. Press any button to stop the beep.



To move to the next page, follow the instructions to the contents of the receiving broadcast.

To return to the FM data broadcast display, press BACK.

## When receiving paging message

When you receive a paging message, you will hear a beeping sound through the headphones and the PAGE indicator will flash at the left side of the display. (There is no icon indication) Press any button to stop the beep. When you display the Paging Message, the PAGE indicator stops flashing and appears.



To see a paging message, use BACK to display the selecting window below, and then press the corresponding Function button to PAGE.

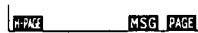

To return to the FM Data Broadcast display, press BACK.

15-EN

Seeing FM Data

### Notes

- When you press H-PAGE program, MSG or PAGE to receive the data, "RECEIVING DATA" will be displayed. If there is no data to be received, approximately after 20 seconds the display will return to the previous screen.

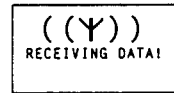

- When the reception is poor, the DATA indicator disappears, but "RECEIVING DATA" will be displayed for approximately 10 seconds. Then "SIGNAL TOO WEAK." will be displayed for approximately 10 seconds and return to the previous display.

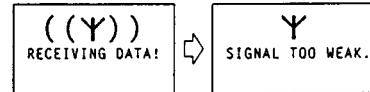

## To receive FM audio broadcast only, to change stations or pre-set stations

Press FM DATA.

## To return to the screen one level above

Press BACK.

## To return to the Home Page

Press the Function button corresponding to H-PAGE on the display window.

16-EN

## Saving Information That You Can See

You can save up to 8 pages of important information that you can recall for later use.

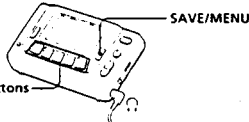

- 1 Display the information you wish to save.
- 2 Press SAVE/MENU.



- 3 Press the Function button corresponding to WRITE on the display.

### Note

If you try to save another page of information when 8 pages of information have already been saved, the message will be displayed (at the right). In this case, delete unnecessary data from the saved information. (For details see "Deleting the Information that Has Been Saved" page 19)

Memory FULL!  
Please delete unnecessary data to create space!  
BACK: Return

17-EN

Seeing FM Data

## To recall information that has been saved

Press SAVE/MENU. Then, press the Function button corresponding to READ on the display window. To scroll to the next page press the Function button corresponding to READ again.

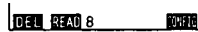

18-EN

## Deleting the Information that Has Been Saved

- 1 Press the Function button corresponding to READ to display the information you want to delete.

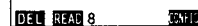

- 2 Press the Function button corresponding to DEL.

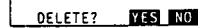

To delete, press the Function button corresponding to YES.

To cancel, press the Function button corresponding to NO.

Seeing FM Data

19-EN

## Setting the Functions

You can set the functions such as Auto Power OFF and Reception Area.

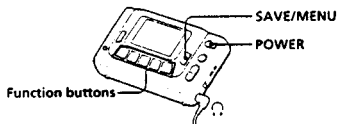

- 1 Press POWER to turn on the unit.
- 2 Press SAVE/MENU.

- 3 Press the Function button corresponding to CONFIG. The Mode I Main Menu will be displayed.



- 4 Press the Function button corresponding to SETUP on the display.

- 5 Press the Function button corresponding to T UP or DWN to move the cursor to the Function Setup, and press the Function button corresponding to ENT. The Function titles will be displayed.

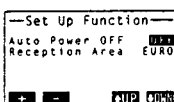

20-EN

### Note

If you enter the "Maintenance Mode" at the "Set Up Menu", press BACK to return to previous display. The Maintenance Mode is not needed for radio operations.

## To set the Auto Power OFF

When you turn this to ON and there is no key operation for 120 minutes while the power is turned on, the power automatically turns off.

- 1 Press the Function button corresponding to T UP or DWN to move the cursor to Auto Power OFF.
- 2 Press the Function button corresponding to + or - to set to either ON or OFF.

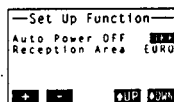

### Note

If there is no key operation during the FM data mode and the DATA indicator is not lit (which means that the FM multiplex broadcast is not received), the FM data mode will be cancelled automatically in about 20 minutes, and only the audio will be received.

Seeing FM Data

21-EN

## To set the Reception Area

To set the format of the receiving signal to the area, select from one of these modes: EURO or USA.

- 1 Press the Function button corresponding to T UP or DWN to move the cursor to Reception Area.

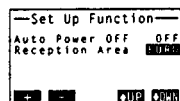

- 2 Press the Function button corresponding to + or - to set to either EURO or USA. When using the unit in the United States of America, set it to USA.

### Note

When you press the Function button corresponding to ID'S on the display, you can see Your ID and Password ID, but it is not needed for the radio operations. Press the Function button corresponding to TOP on the display to return to the previous display. (For details see "ID Numbers" page 23)

22-EN

## Additional Information

### ID Numbers

ID refers to the following three ID numbers.  
 Your ID: for personal messaging (Radio Paging Message) services.  
 DDJ Group ID: for group information services.  
 Password ID: for free additional information services.  
 These ID Numbers are factory set. You do not need to register or confirm these ID Numbers for radio operation. If the service company contacts you, follow the steps below.

- 1 Press **POWER** to turn on the unit.
- 2 Press **SAVE/MENU**.
- 3 Press the Function button corresponding to **CONFIG** on the display.
- 4 Press the Function button corresponding to **ID'S** on the display.

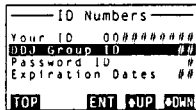

At this display you can confirm Your ID of which receivers individually has as a Receiver ID.

23-EN

Additional Information

### To confirm the DDJ Group ID

Press the Function button corresponding to **↑ UP** or **↓ DWN** to move the cursor to the "DDJ Group ID", press the Function button corresponding to **ENT** to select the DDJ Group ID.

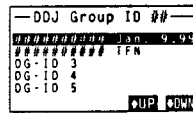

When the DDJ Group ID is registered, the ID Number and Expiration dates appear in the display. You can register up to 12 subscription services of DDJ-ID. Press the Function button corresponding to **↑ UP** and **↓ DWN** to scroll the display. If the Expiration Date is displayed as TFN, it is for an indefinite period of time.

24-EN

### To confirm the Password ID

Press the Function button corresponding to **↑ UP** or **↓ DWN** to move the cursor to the Password ID, and press the Function button corresponding to **ENT** to select the Password ID.

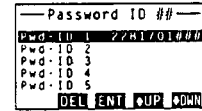

When the Password ID is registered, the ID Number appears in the display. You can register up to 8 passwords. Press the Function button corresponding to **↑ UP** and **↓ DWN** to scroll the display.

25-EN

Additional Information

### To register and correct the Password ID

Press the Function button corresponding to **↑ UP** or **↓ DWN** to move the cursor to an empty Password ID or a Password ID to correct at the display above, and press the Function button corresponding to **ENT** to switch over the display to a Password ID editing display.

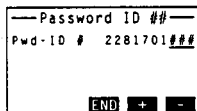

Press the Function button corresponding to **+ -** to enter the value of the Password ID. The range of the value is 2281701376 to 2281701631. After setting the value range, press the Function button corresponding to **END** to input and finish the setting.

### To confirm the Expiration Dates

Press the Function button corresponding to **↑ UP** or **↓ DWN** to move the cursor to the Expiration Dates. Press the Function button corresponding to **ENT** to select the Expiration Dates.

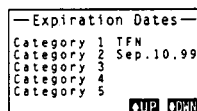

When the Expiration Dates is registered, the Expiration date appears in the display. You may register up to 15 Expiration Dates. Press the Function button corresponding to **↑ UP** and **↓ DWN** to scroll the display.

26-EN

Additional Information

## Using the Stand

Lift and use the stand on the base of the unit to see the display at an optimum angle.

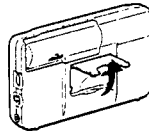

## Precautions

- Operate the unit only on 1.5 V DC with two R6 (size AA) batteries.
- Avoid exposure to temperature extremes, direct sunlight, moisture, sand, dust or mechanical shock. Never leave the unit in a car parked in the sun.
- Should anything fall into the unit, remove the batteries and have the unit checked by qualified personnel before operating it any further.
- To clean the casing, use a soft cloth dampened with a mild detergent solution.
- In vehicles or buildings, radio reception may be difficult or noisy. Try listening near a window.

### Notes on Headphones

#### Road safety

Do not use headphones while driving, cycling, or operating any motorized vehicle. It may create a traffic hazard and is illegal in many areas. It can also be potentially dangerous to play your headphones at high volume while walking, especially at pedestrian crossings. You should exercise extreme caution or discontinue use in potentially hazardous situations.

#### Preventing hearing damage

Avoid using headphones at high volume. Hearing experts advise against continuous, loud and extended play. If you experience a ringing in your ears, reduce volume or discontinue use.

#### Caring for others

Keep the volume at a moderate level. This will allow you to hear outside sounds and to be considerate to people around you.

27-EN

28-EN

Additional Information

### Warning

If there is lightning when you are using the unit, take off the headphones immediately.

If you have any questions or problems concerning your unit, please consult your nearest Sony dealer.

29-EN

## SECTION 2 DISASSEMBLY

● The equipment can be removed using the following procedure.

Set → Cabinet (Rear) → Main board → MICOM board, LCD1

**Note :** Follow the disassembly procedure in the numerical order given.

### 2-1. CABINET (REAR) REMOVAL

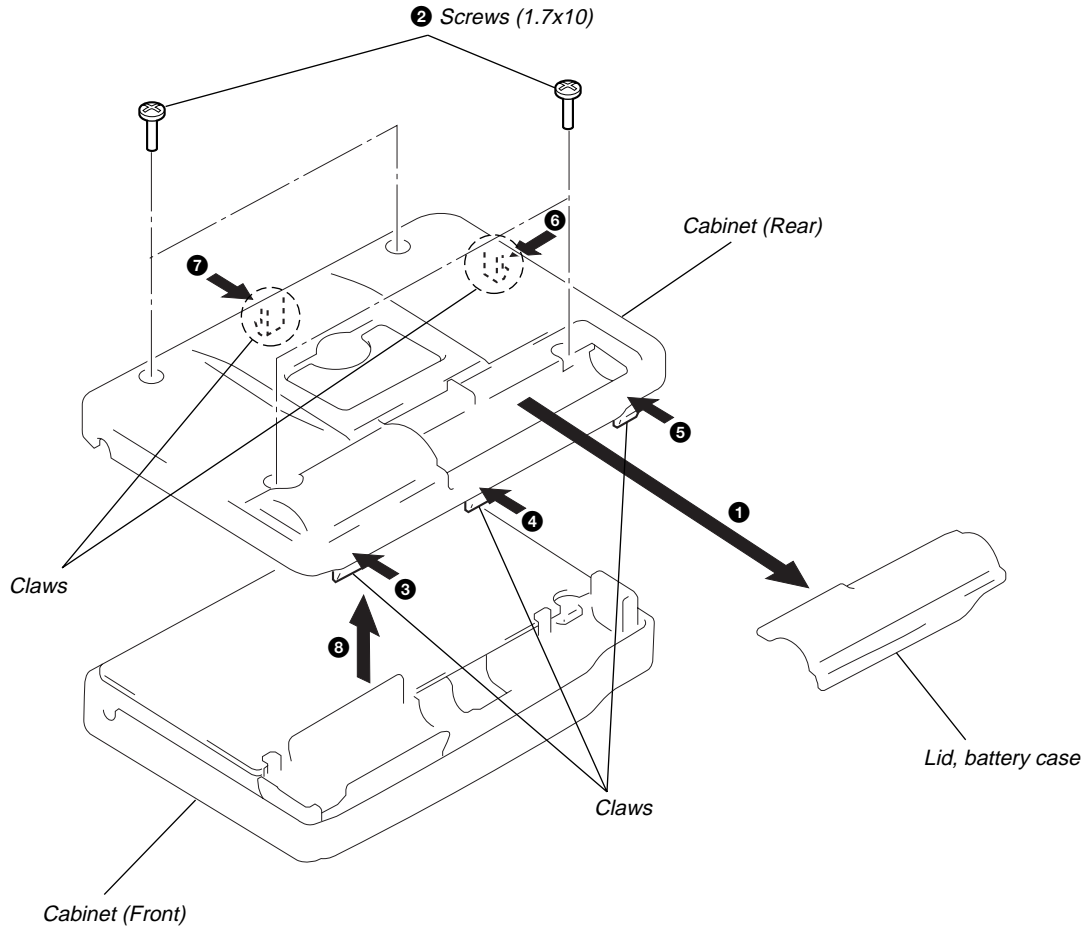

### 2-2. MAIN BOARD REMOVAL

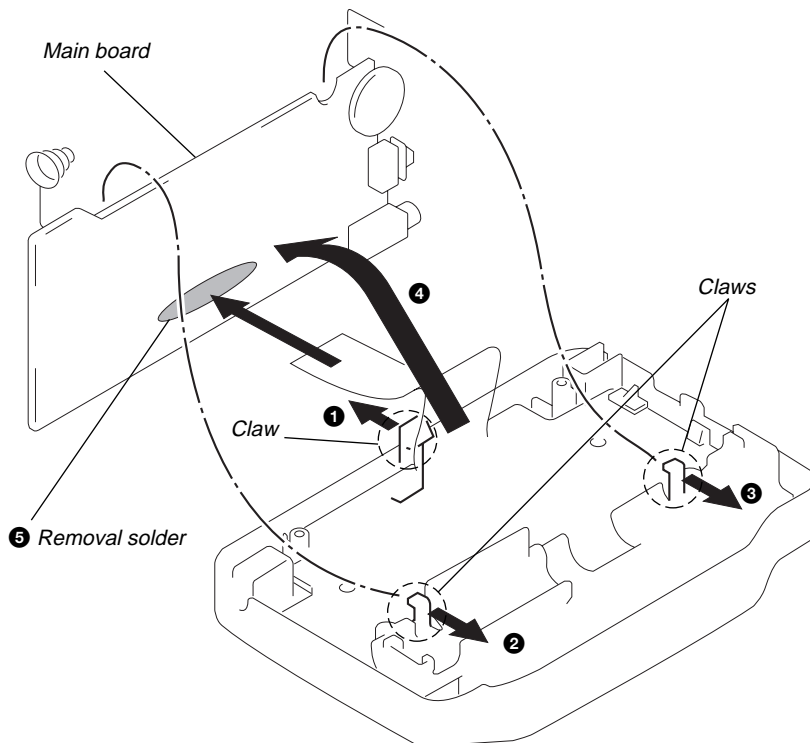

**2-3. MICOM BOARD, LCD1 REMOVAL**

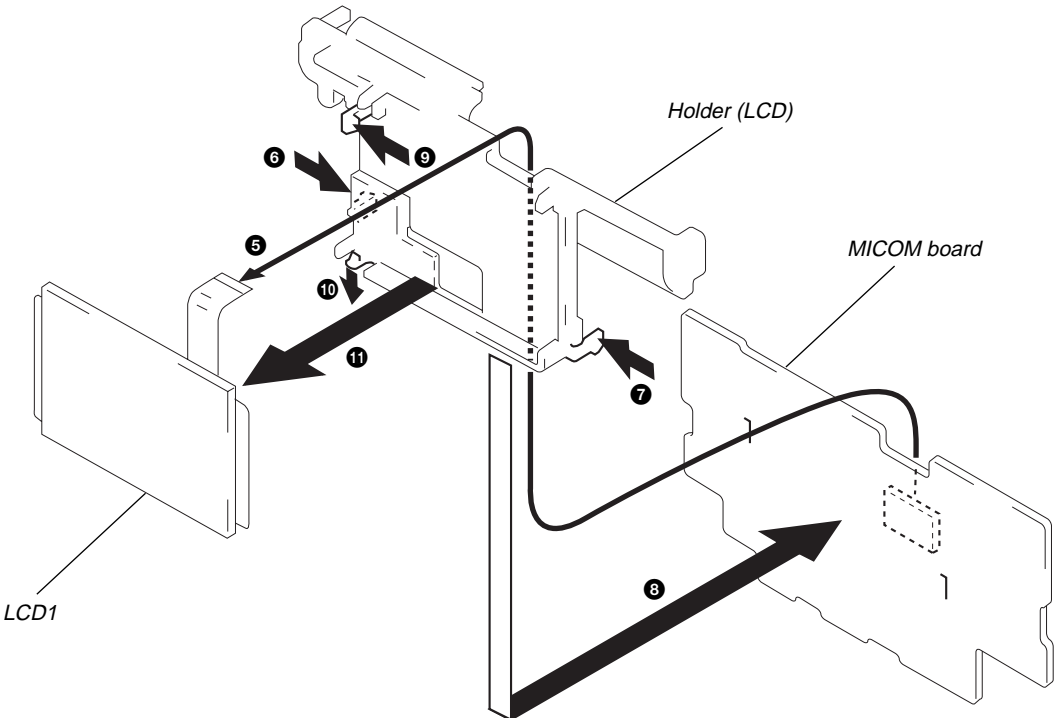
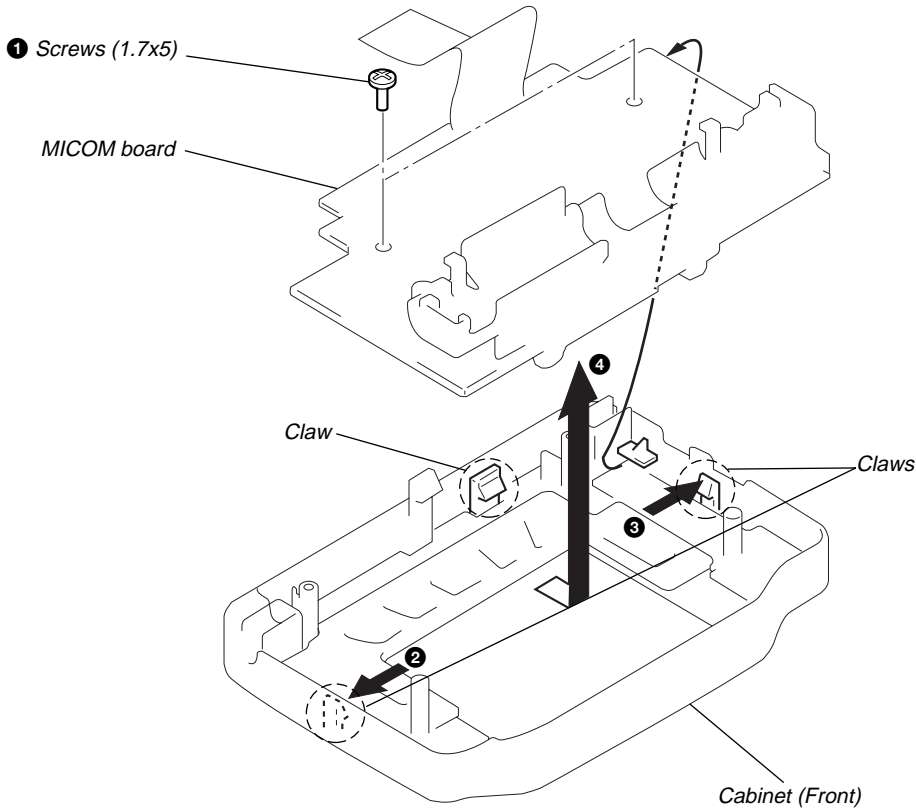

# SECTION 3 ELECTRICAL ADJUSTMENTS

## FM Section

### Setting :

VOLUME : Maximum

FM RF signal generator

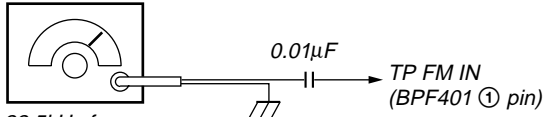

22.5kHz frequency deviation by 400Hz signal.  
Output level : as low as possible

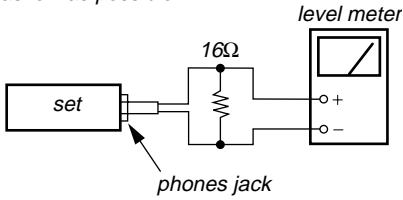

- Repeat the procedures in each adjustment several times, and the tracking adjustments should be finally the trimmer capacitors.

FM IF ALIGNMENT	
Adjust for a maximum reading on level meter.	
T401	10.7MHz

FM TRACKING ADJUSTMENT	
Adjust for a maximum reading on level meter.	
CT402	98.0MHz

### Adjustments Location :

[MAIN BOARD]  
(Side A)

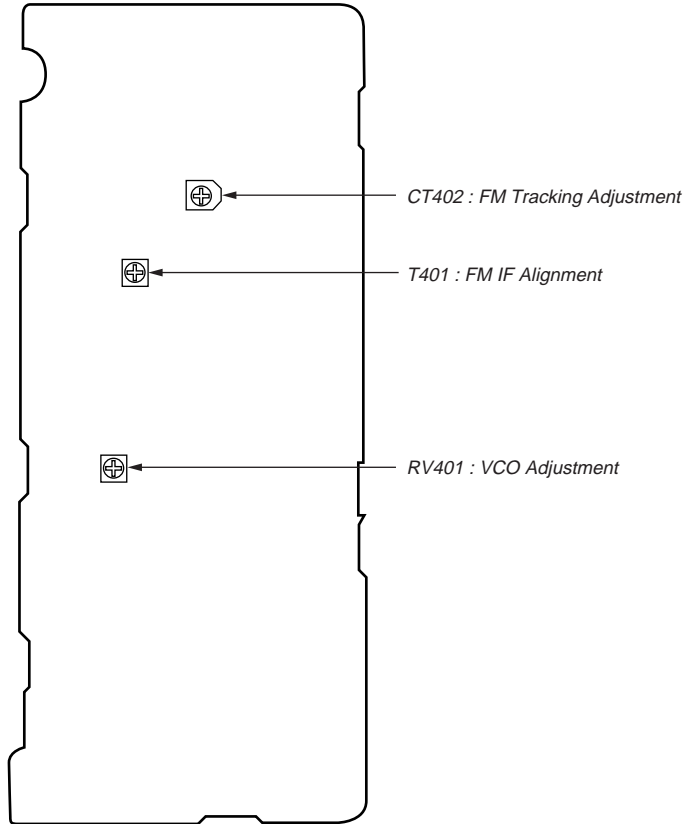

## FM VCO Adjustment

### Procedure :

[MAIN BOARD] (Side A)

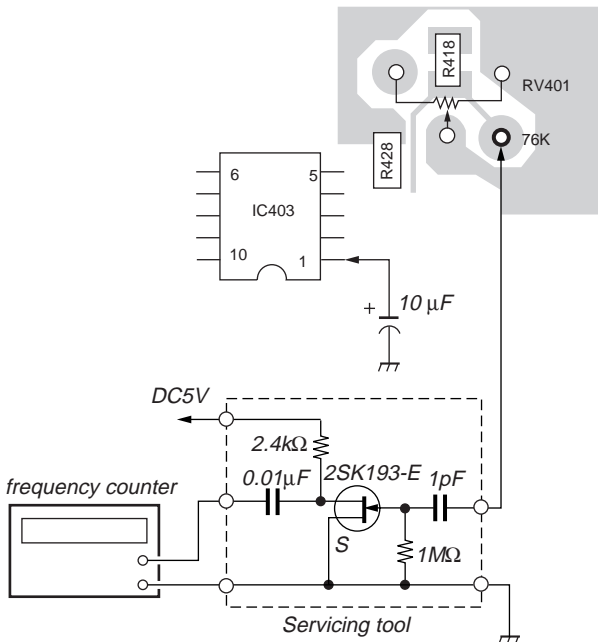

- Connect a capacitor (10µF) between pin ① of IC403 and ground.
- Adjust RV401 for 76.2kHz – 75.8kHz reading on the frequency counter.

## SECTION 4 DIAGRAMS

### 4-1. EXPLANATION OF IC TERMINALS

#### IC101 MSM65587 (MAIN SYSTEM CONTROL)

Pin No.	Pin name	I/O	Description
1	MUTE	O	Mute signal output.
2	BEEP	O	Beep signal output.
3	DEC INT	I	Interrupt signal input from decoder IC (IC204).
4	$\overline{\text{BUSY}}$	I	Busy signal input from DE-SCRAMBLE MICOM (IC301).
5	F3	I	Function 3 key input.
6	F5	I	Function 5 key input.
7	F4	I	Function 4 key input.
8	(-)	I	Tune (-) key input.
9	VDD	-	Power supply (+3V).
10	VREF	-	Voltage reference terminal.
11	AGND	-	Ground for analog.
12 - 15	AI0 - AI3	-	Not used (Ground connect).
16	GND	-	Ground.
17	VDD	-	Power supply (+3V).
18	READY PLL	I	Input PLL ready OK signal.
19	REQ PLL	O	PLL communication request output terminal.
20	DATA PLL	O	PLL serial data output terminal.
21	CLOCK PLL	O	PLL serial clock output terminal.
22	DI EEP	I	Data read input from EEPROM.
23	DO EEP	O	Data write output to EEPROM.
24	CLK EEP	O	Clock output to EEPROM.
25	CS EEP	O	Chip select output to EEPROM.
26	F2	I	Function 2 key input.
27	DISPLAY	I	Display (FM data) key input.
28	SAVE	I	Save key input.
29	F1	I	Function 1 key input.
30	ENTER	I	Enter key input.
31	BACK	I	Back key input.
32	FLA CLK	-	Not used ("H" level).
33	FLA DAT	-	Not used ("H" level).
34	$\overline{\text{RES}}$	I	System reset terminal.
35	NMI		Not used ("H" level).
36	$\overline{\text{EA}}$	I	Internal memory selection. "H" : Active
37	VDD	-	Power supply (+3V).
38	OSC0	I	Main system clock oscillator (4.9152 MHz).
39	$\overline{\text{OSS1}}$	O	Main system clock oscillator (4.9152 MHz).
40	GND	-	Ground.
41	OSC CNT	O	Clock oscillator control.
42 - 46		-	Not used (Open).
47	$\overline{\text{RD}}$	O	External memory read output. "L" : Reading
48	$\overline{\text{WR}}$	O	External memory write output. "L" : Writing
49		-	Not used (Open).
50	ALE	O	Address latch signal output to external memory.
51 - 58	D0 - D7	I/O	Address / data bus input / output to external memory.
59 - 65	A8 - A14	O	Address bus output to external memory.
66		-	Not used (Open).
67	VDD	-	Power supply (+3V).
68	GND	-	Ground.

Pin No.	Pin name	I/O	Description
69	A15	O	Address bus output to external memory.
70	A16	O	Address bus output to external memory.
71, 72		–	Not used (Open).
73	CS DEC	O	Chip select output to decoder (IC204).
74	CS RAM	O	Chip select output to RAM (IC202).
75	CS ROM	O	Chip select output to ROM (IC203).
76	DEC RES	O	Reset signal output to decoder (IC204).
77 - 78		–	Not used (Open).
81	RESET	O	Reset signal output to DE-SCRAMBLE MICOM (IC301).
82	DD RDY	I	De-scramble end signal input.
83	CLK	O	Clock output to DE-SCRAMBLE MICOM (IC301).
84	DI	O	Data output to DE-SCRAMBLE MICOM (IC301).
85	DO	I	Data input from DE-SCRAMBLE MICOM (IC301).
86	INT	O	De-scramble request signal output.
87	POWER	O	Radio power supply ON/OFF control. “H” : Radio power ON
88	(+)	I	Tune (+) key input.
89	SRAM CHECK	I	SRAM check terminal.
90	A0 LCD	O	Communications with LCD module.
91	CS LCD	O	Communications with LCD module.
92	RES LCD	O	Communications with LCD module.
93	VDD	–	Power supply (+3V).
94	GND	–	Ground.
95	VDET	I	Low voltage (1.9V) DET. “L” : power OFF
96	POWER SW	I	Power ON/OFF key input.
97	EXT (IN)	I	External (Beep) signal input.
98	DATA LCD	O	Serial data output to LCD module.
99	EXT (OUT)	O	External (Beep) signal output.
100	SCL LCD	O	Serial clock output to LCD module.

**IC204 (MSM9553) DECODER**

Pin No.	Pin name	I/O	Description
1	MON	–	Not used (Open).
2	ADET IN	I	Analog signal input for test (connected ground).
3	AVDD	–	Power supply terminal for analog (+3.5V).
4	AGND	–	Ground terminal for analog (ground).
5	SG	O	Reference voltage terminal for analog.
6	AIN	I	FM multiplex signal input terminal.
7	$\overline{\text{XOUTC}}$	–	Not used (Open).
8 - 14	MOUT0 - MOUT6	–	Not used (Open).
15	$\overline{\text{INT}}$	O	interrupt signal output to MICOM (IC101).
16	$\overline{\text{WR}}$	I	Write signal input terminal to internal register.
17	NC	–	Not used (Open).
18	$\overline{\text{RD}}$	I	Ready signal input terminal to internal register.
19 - 26	D0 - D7	I/O	Data bus signal input/output terminal to internal register.
27	KGND	–	Ground terminal for digital.
28	DVDD	–	Power supply terminal for digital.
29	XTAL1	I	Oscillator connection terminal (8.192MHz).
30	XTAL2	O	Oscillator connection terminal (8.192MHz).
31	$\overline{\text{CS}}$	I	Chip select signal input terminal.
32	XOUT	–	Not used (Open).
33 - 38	A0 - A5	I	Address signal input terminal to internal register.
39	NC	–	Not used (Open).
40	$\overline{\text{CLR}}$	I	Internal register is reset at “L” setting power down status.
41	$\overline{\text{IORD}}$	–	Not used (Open).
42	$\overline{\text{IOWR}}$	–	Not used (Open).
43,44	NC	–	Not used (Open).

**IC301 MSM 69231-GS-2K (DE-SCRAMBLE MICOM)**

Pin No.	Pin name	I/O	Description
1		–	Not used (Open).
2	DO	O	De-scramble data output.
3	DI	I	De-scramble data input.
4	CLK	I	Serial clock input.
5	$\overline{\text{RESET}}$	I	Input signal input.
6, 7		–	Not used (Open).
8	INT		Input terminal for external de-scramble request signal.
9 – 13		–	Not used (Open).
14	OSC1	O	Main system clock oscillator (4.9152MHz).
15	OSC0	I	Main system clock oscillator (4.9152MHz).
16	GND	–	Ground.
17	OSC CONT	O	Clock oscillator control.
18 – 28		–	Not used (Open).
29	EA	I	Test terminal (Must be connected to VDD).
30 – 38		–	Not used (Open).
39	VDD	–	Power supply (+3.2V).
40		–	Not used (Open).
41	$\overline{\text{DDRDY}}$	O	De-scramble end signal output to external.
42	$\overline{\text{BUSY}}$	O	Busy signal output to external.
43, 44		–	Not used (Open).

**IC501 ( $\mu$  PD17015G) DTS MICROCOMPUTER**

Pin No.	Pin name	I/O	Description
1	REQ	I	Communication request signal input.
2	READY	O	Output communication OK signal output.
3 - 5	PC1 - PC3	–	Not used (Open).
6	BEEP	–	Not used (Open).
7	DATA	I	PLL data input terminal.
8	CLK	I	PLL clock input terminal.
9, 10	PA2, PA3	–	Not used (Open).
11	CE	–	Not used (VDD connection).
12	XOUT	O	Clock oscillator connection terminal.
13	XIN	I	Clock oscillator connection terminal.
14	VDD	–	Power supply (+3V).
15	GND	–	Ground.
16	EO	O	PLL error output terminal.
17	VREG	–	Voltage REG terminal.
18	VCOH	–	Input local oscillator (VCO) output.
19	VCOL	–	Not used (Open).
20 - 28	LCD8 - LCD0	–	Not used (Open).
29 - 32	COM3 - COM0	–	Not used (Open).
33	VLCD1	–	Not used (Open).
34, 35	CAP1, CAP0	–	Not used (Open).
36	VLCD0	–	Not used (Open).
37, 38	PB0, PB1	–	Not used (Open).

4-2. BLOCK DIAGRAM

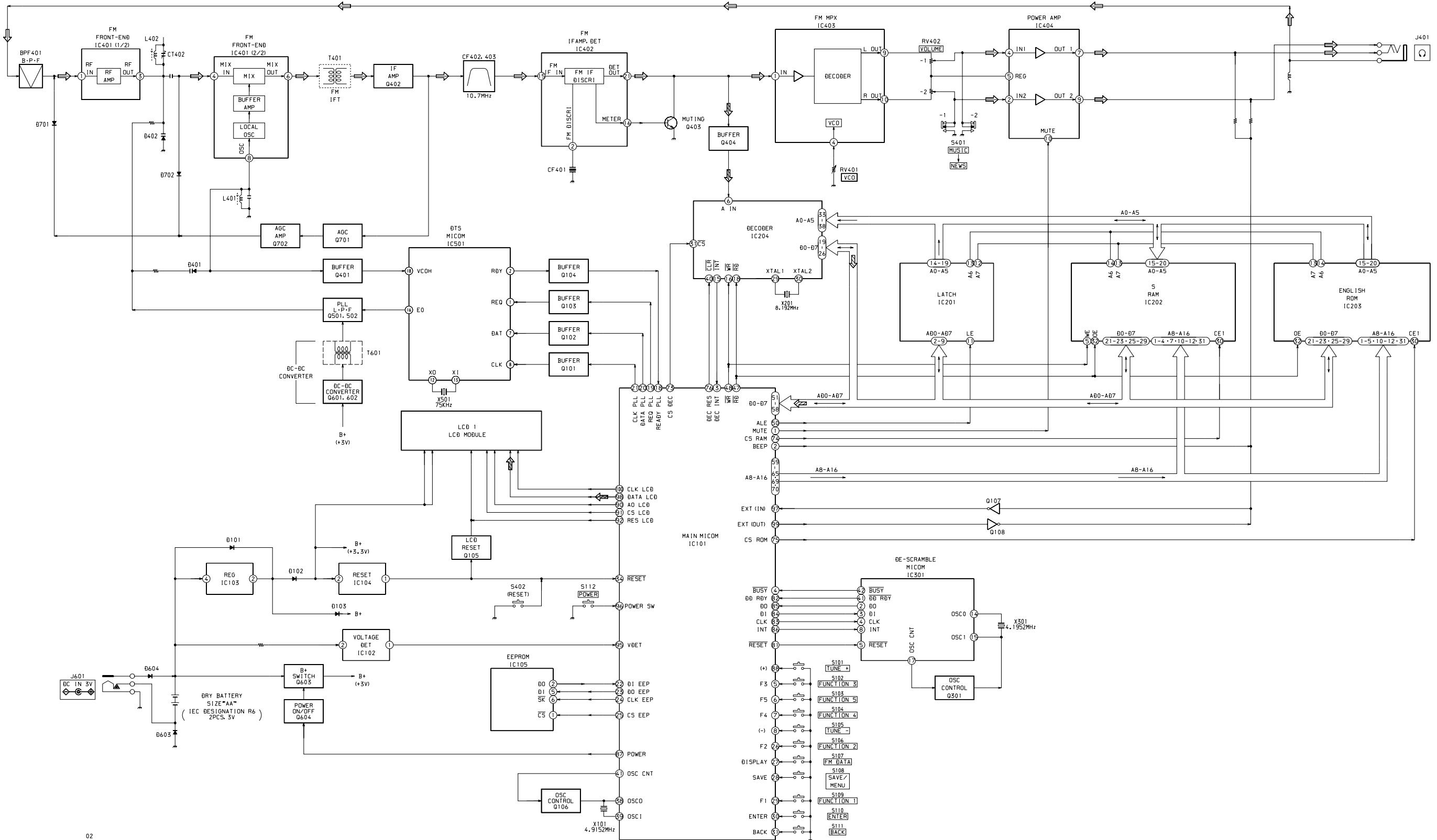

02

• Signal path.  
 ◀ : FM  
 ⇄ : Multiplex

4-4. SCHEMATIC DIAGRAM (MAIN SECTION) ● Refer to page 23 for IC Block Diagrams.

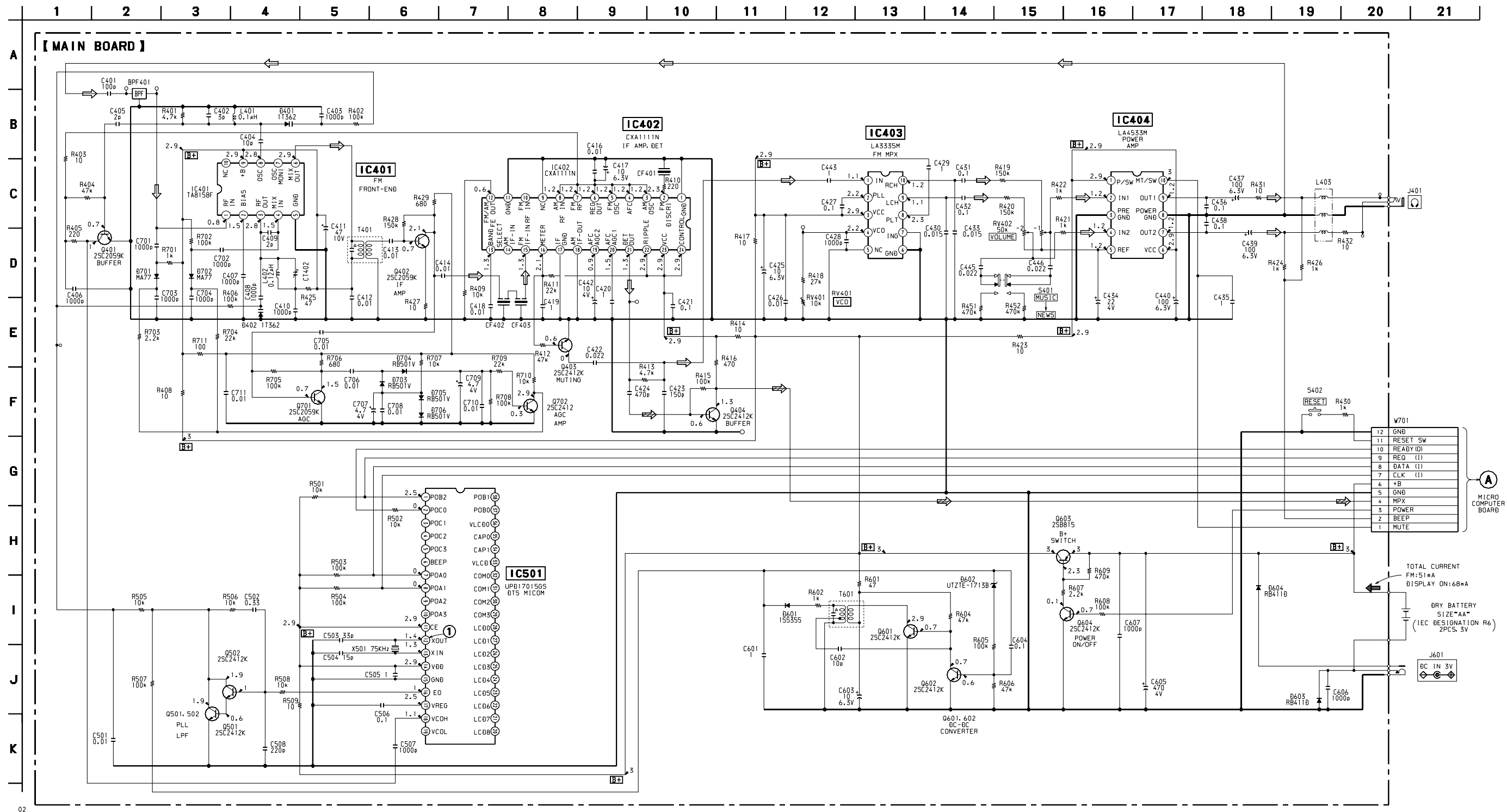

- Note:**
- All capacitors are in  $\mu\text{F}$  unless otherwise noted.  $\text{pF}$ :  $\mu\text{F}$  50 WV or less are not indicated except for electrolytics and tantalums.
  - All resistors are in  $\Omega$  and  $1/4\text{W}$  or less unless otherwise specified.
  - $\Delta$ : internal component.
  - B+**: B+ Line.
  - +**: adjustment for repair.
  - Power voltage is dc 3V and fed with regulated dc power supply from external power voltage jack.
  - Voltages and waveforms are dc with respect to ground under no-signal (detuned) conditions. no mark : FM
  - Voltages are taken with a VOM (Input impedance 10 M $\Omega$ ). Voltage variations may be noted due to normal production tolerances.
  - Waveforms are taken with an oscilloscope. Voltage variations may be noted due to normal production tolerances.
  - Circled numbers refer to waveforms.

- Signal path.
- $\Rightarrow$  : FM
- $\Rightarrow$  : Multiplex

● WAVEFORM (MAIN SECTION)

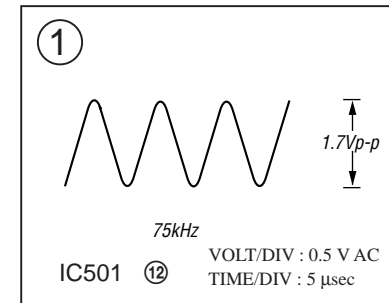

● WAVEFORMS (MICOM SECTION)

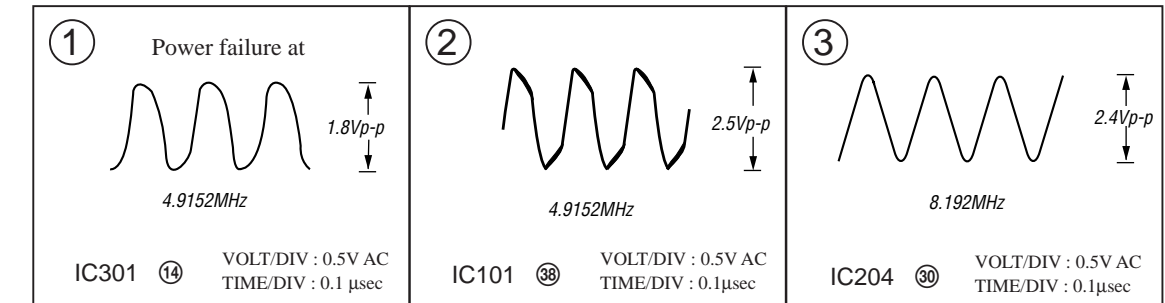

4-6. SCHEMATIC DIAGRAM (MICOM SECTION) ● Refer to page 18 for Waveforms. ● Refer to page 23 for IC Block Diagrams.

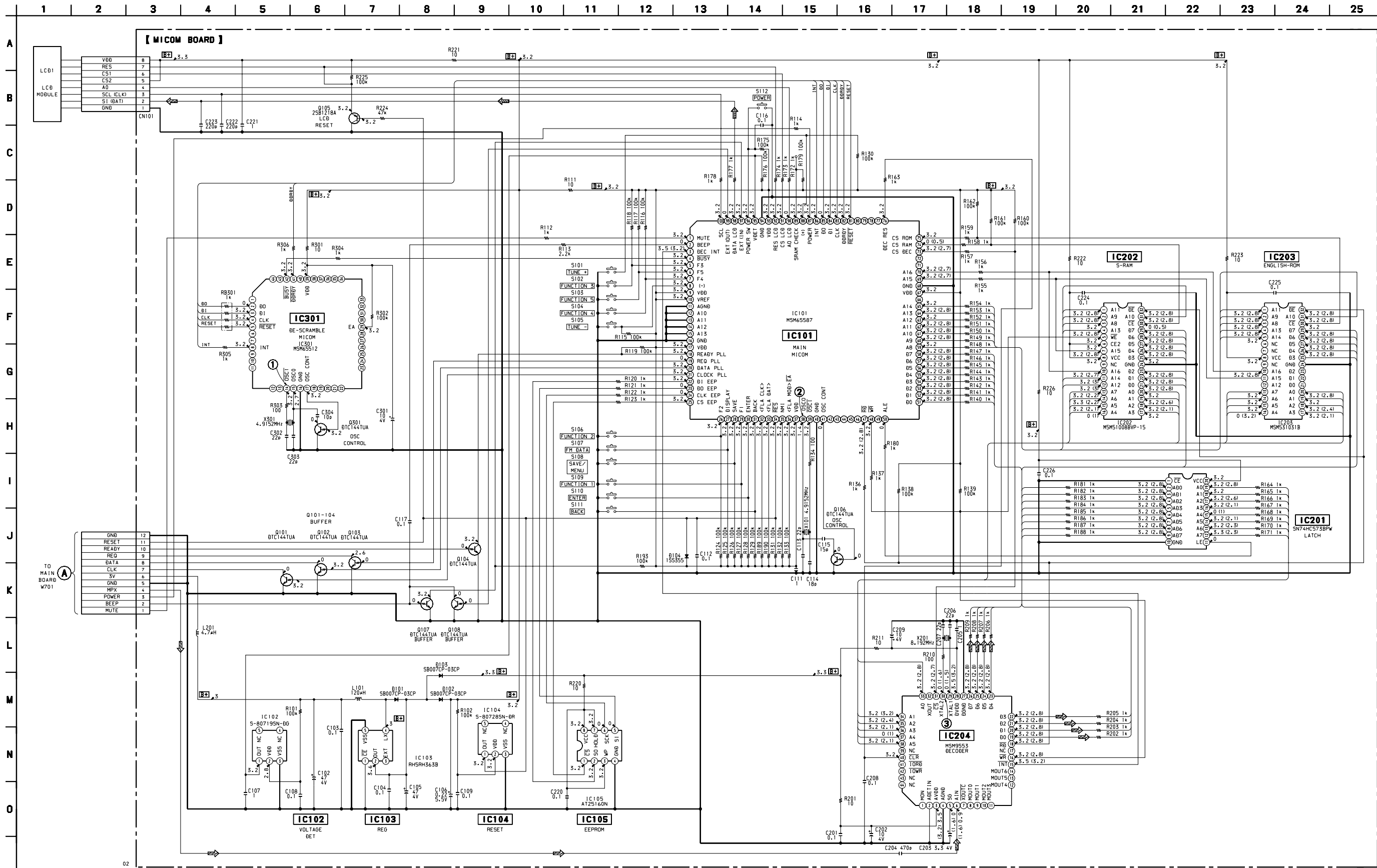

**Note:**

- : parts extracted from the component side.
- : Through hole.
- ▨ : Pattern from the side which enables seeing. (The other layers' patterns are not indicated.)

**Caution:**

Pattern face side: (Conductor Side)	Parts on the pattern face side seen from the pattern face are indicated.
Parts face side: (Component Side)	Parts on the parts face side seen from the parts face are indicated.

**Note:**

- All capacitors are in  $\mu\text{F}$  unless otherwise noted.  $\text{pF}$ :  $\mu\text{F}$  50 WV or less are not indicated except for electrolytics and tantalums.
- All resistors are in  $\Omega$  and  $1/4\text{W}$  or less unless otherwise specified.
- ① : B+ Line.
- Power voltage is dc 3 V and fed with regulated dc power supply from external power voltage jack.

- Voltagess and waveforms are dc with respect to ground under no-signal (detuned) conditions.
- ( ) : Multiplex
- Voltagess are taken with a VOM (Input impedance 10 M $\Omega$ ). Voltage variations may be noted due to normal production tolerances.

- Waveforms are taken with an oscilloscope. Voltage variations may be noted due to normal production tolerances.
- Circled numbers refer to waveforms.
- Signal path.
- ▨ : Multiplex

● IC BLOCK DIAGRAMS

IC401 TA8158F (ER)

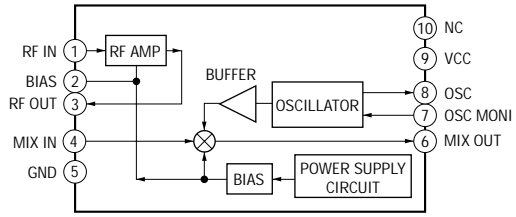

IC403 LA3335M

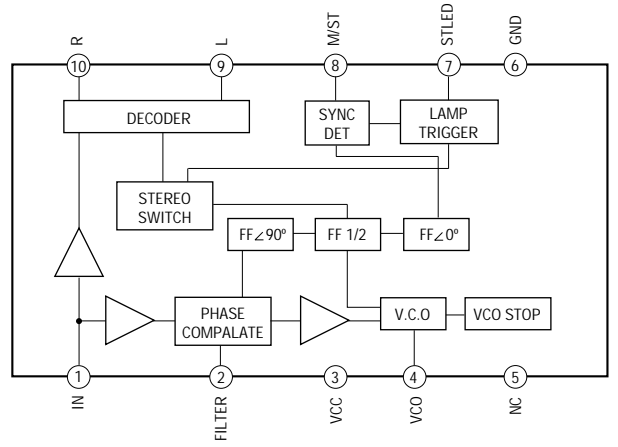

IC402 CXA1111N

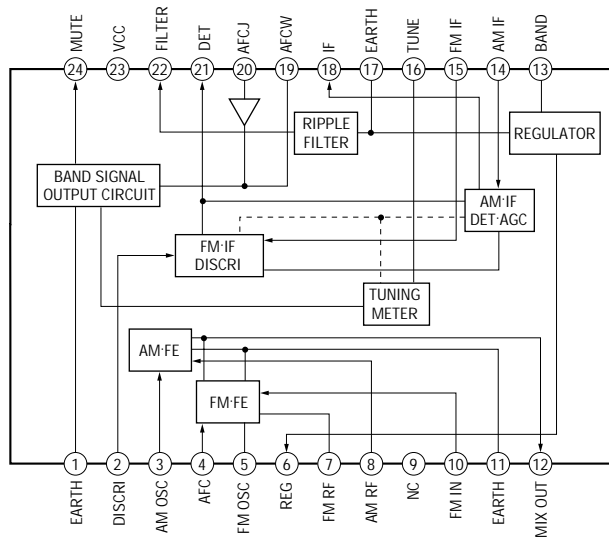

IC404 LA4533M

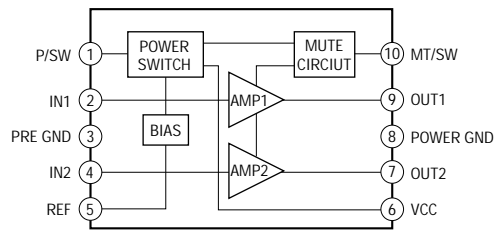

## SECTION 5 EXPLODED VIEW

**NOTE :**

- -XX, -X mean standardized parts, so they may have some difference from the original one.
- Items marked “\*” are not stocked since they are seldom required for routine service. Some delay should be anticipated when ordering these items.
- The mechanical parts with no reference number in the exploded views are not supplied.
- Accessories and packing materials are given in the last of this parts list.

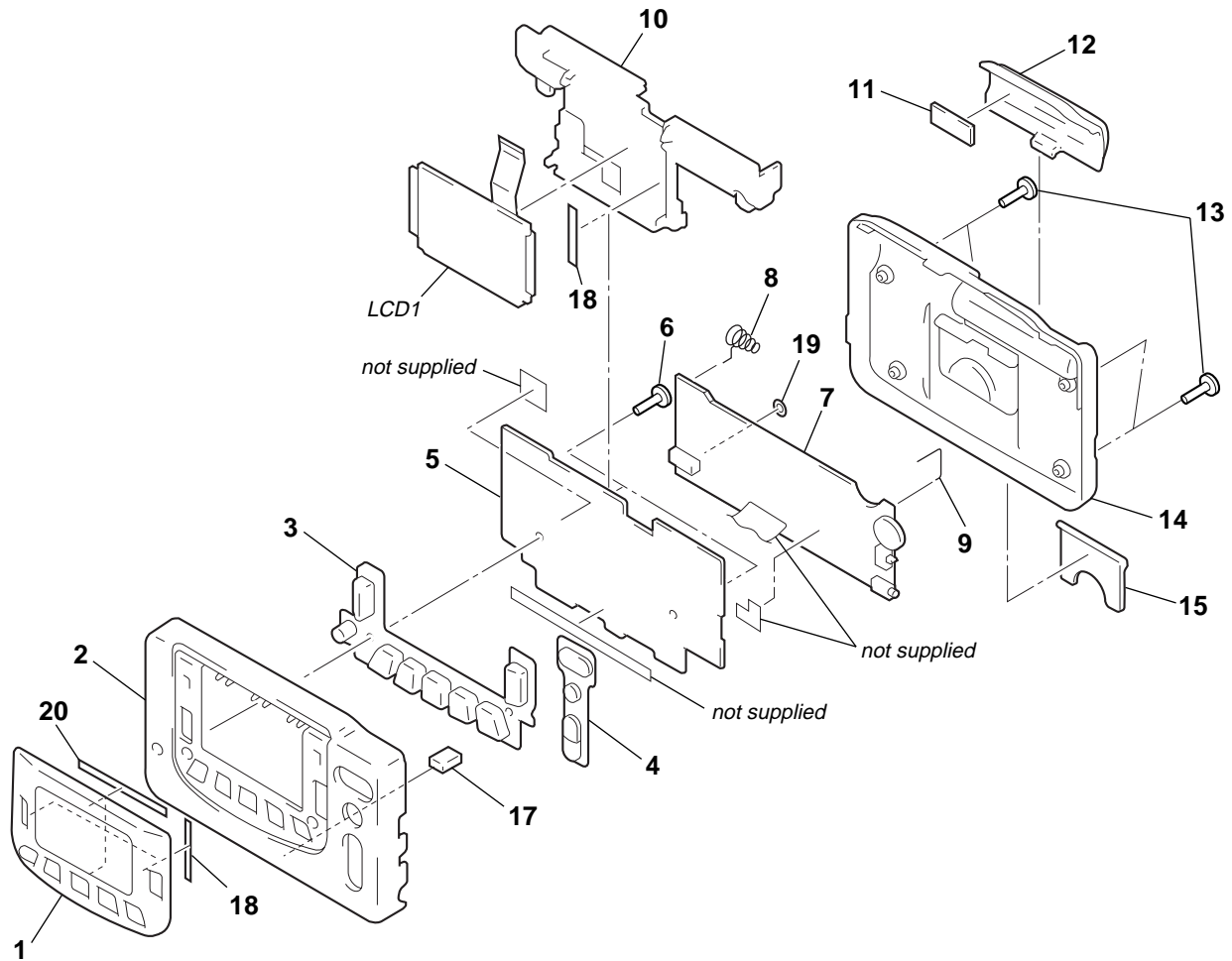

Ref. No.	Part No.	Description	Remark	Ref. No.	Part No.	Description	Remark
1	3-930-536-11	PANEL		11	3-936-441-01	CUSHION (BATTERY CASE LID)	
2	3-930-534-11	CABINET (FRONT)		12	3-930-591-21	LID, BATTERY CASE	
3	1-762-590-21	SWITCH, RUBBER KEY (MENU)		13	3-910-063-01	SCREW (1.7X10)	
4	1-762-591-21	SWITCH, RUBBER KEY (POWER)		14	3-930-583-21	CABINET (REAR)	
* 5	A-3663-105-A	MICOM BOARD, COMPLETE		15	3-930-593-21	STAND	
6	3-374-079-01	SCREW (1.7X5), TAPPING		* 17	3-698-057-01	STOPPER, B1	
* 7	A-3683-003-A	MAIN BOARD, COMPLETE		18	3-027-525-01	CUSHION	
8	3-930-599-01	TERMINAL (-), BATTERY		19	3-027-608-01	SPACER (DIA. 3)	
9	3-930-598-01	TERMINAL (+), BATTERY		20	3-572-550-01	CUSHION (A)	
* 10	3-930-535-01	HOLDER (LCD)		LCD1	1-801-152-11	LCD MODULE	



**MAIN**

Ref. No.	Part No.	Description	Remark	Ref. No.	Part No.	Description	Remark
		< TRIMMER >					
CT402	1-141-304-21	CAP, TRIMMER 10PF		R408	1-216-001-00	METAL CHIP 10 5% 1/10W	
		< DIODE >		R409	1-216-073-00	METAL CHIP 10K 5% 1/10W	
D401	8-713-100-11	DIODE 1T362		R410	1-216-033-00	METAL CHIP 220 5% 1/10W	
D402	8-713-100-11	DIODE 1T362		R411	1-216-081-00	METAL CHIP 22K 5% 1/10W	
D601	8-719-988-62	DIODE 1SS355		R412	1-216-089-91	RES,CHIP 47K 5% 1/10W	
D602	8-719-977-40	DIODE UDZ-TE-17-13B		R413	1-216-065-91	RES,CHIP 4.7K 5% 1/10W	
D603	8-719-975-40	DIODE RB411D		R414	1-216-001-00	METAL CHIP 10 5% 1/10W	
D604	8-719-975-40	DIODE RB411D		R415	1-216-097-91	RES,CHIP 100K 5% 1/10W	
D701	8-719-421-40	DIODE MA77		R416	1-216-041-00	METAL CHIP 470 5% 1/10W	
D702	8-719-421-40	DIODE MA77		R417	1-216-001-00	METAL CHIP 10 5% 1/10W	
D703	8-719-058-24	DIODE RB501V-40TE-17		R418	1-216-083-00	METAL CHIP 27K 5% 1/10W	
D704	8-719-058-24	DIODE RB501V-40TE-17		R419	1-216-101-00	METAL CHIP 150K 5% 1/10W	
D705	8-719-058-24	DIODE RB501V-40TE-17		R420	1-216-101-00	METAL CHIP 150K 5% 1/10W	
D706	8-719-058-24	DIODE RB501V-40TE-17		R421	1-216-049-91	RES,CHIP 1K 5% 1/10W	
		< IC >		R422	1-216-049-91	RES,CHIP 1K 5% 1/10W	
IC401	8-759-493-45	IC TA8158F(ER)		R423	1-216-001-00	METAL CHIP 10 5% 1/10W	
IC402	8-752-065-30	IC CXA1111N		R424	1-216-049-91	RES,CHIP 1K 5% 1/10W	
IC403	8-759-804-98	IC LA3335M		R425	1-216-017-91	RES,CHIP 47 5% 1/10W	
IC404	8-759-802-75	IC LA4533M		R426	1-216-049-91	RES,CHIP 1K 5% 1/10W	
IC501	8-759-379-75	IC uPD17015GS-526-GJG-E1		R427	1-216-001-00	METAL CHIP 10 5% 1/10W	
		< JACK >		R428	1-216-101-00	METAL CHIP 150K 5% 1/10W	
J401	1-563-857-11	JACK, HEADPHONE (♂)		R429	1-216-045-00	METAL CHIP 680 5% 1/10W	
J601	1-580-372-11	JACK,DC(POLARITY UNIFIED TYPE)	(DC IN 3V)	R430	1-216-049-91	RES,CHIP 1K 5% 1/10W	
		< COIL >		R431	1-216-001-00	METAL CHIP 10 5% 1/10W	
L201	1-412-002-31	CHIP INDUCTOR 4.7uH		R432	1-216-001-00	METAL CHIP 10 5% 1/10W	
L401	1-410-807-11	INDUCTOR 0.1uH		R451	1-216-113-00	METAL CHIP 470K 5% 1/10W	
L402	1-410-730-11	INDUCTOR CHIP 0.12uH		R452	1-216-113-00	METAL CHIP 470K 5% 1/10W	
L403	1-411-393-11	COIL, TRAP		R501	1-216-073-00	METAL CHIP 10K 5% 1/10W	
		< TRANSISTOR >		R502	1-216-073-00	METAL CHIP 10K 5% 1/10W	
Q401	8-729-920-38	TRANSISTOR 2SC2059K-N		R503	1-216-097-91	RES,CHIP 100K 5% 1/10W	
Q402	8-729-920-38	TRANSISTOR 2SC2059K-N		R504	1-216-097-91	RES,CHIP 100K 5% 1/10W	
Q403	8-729-620-06	TRANSISTOR 2SC3052-EF		R505	1-216-073-00	METAL CHIP 10K 5% 1/10W	
Q404	8-729-620-06	TRANSISTOR 2SC3052-EF		R506	1-216-073-00	METAL CHIP 10K 5% 1/10W	
Q501	8-729-620-06	TRANSISTOR 2SC3052-EF		R507	1-216-097-91	RES,CHIP 100K 5% 1/10W	
Q502	8-729-620-06	TRANSISTOR 2SC3052-EF		R508	1-216-073-00	METAL CHIP 10K 5% 1/10W	
Q601	8-729-620-06	TRANSISTOR 2SC3052-EF		R509	1-216-001-00	METAL CHIP 10 5% 1/10W	
Q602	8-729-620-06	TRANSISTOR 2SC3052-EF		R601	1-216-017-91	RES,CHIP 47 5% 1/10W	
Q603	8-729-800-71	TRANSISTOR 2SB815B7-TB		R602	1-216-049-91	RES,CHIP 1K 5% 1/10W	
Q604	8-729-620-06	TRANSISTOR 2SC3052-EF		R604	1-216-089-91	RES,CHIP 47K 5% 1/10W	
Q701	8-729-920-38	TRANSISTOR 2SC2059K-N		R605	1-216-097-91	RES,CHIP 100K 5% 1/10W	
Q702	8-729-620-06	TRANSISTOR 2SC3052-EF		R606	1-216-089-91	RES,CHIP 47K 5% 1/10W	
		< RESISTOR >		R607	1-216-057-00	METAL CHIP 2.2K 5% 1/10W	
R401	1-216-065-91	RES,CHIP 4.7K 5% 1/10W		R608	1-216-097-91	RES,CHIP 100K 5% 1/10W	
R402	1-216-097-91	RES,CHIP 100K 5% 1/10W		R609	1-216-113-00	METAL CHIP 470K 5% 1/10W	
R403	1-216-001-00	METAL CHIP 10 5% 1/10W		R701	1-216-049-91	RES,CHIP 1K 5% 1/10W	
R404	1-216-089-91	RES,CHIP 47K 5% 1/10W		R702	1-216-097-91	RES,CHIP 100K 5% 1/10W	
R405	1-216-033-00	METAL CHIP 220 5% 1/10W		R703	1-216-057-00	METAL CHIP 2.2K 5% 1/10W	
R406	1-216-097-91	RES,CHIP 100K 5% 1/10W		R704	1-216-081-00	METAL CHIP 22K 5% 1/10W	
				R705	1-216-097-91	RES,CHIP 100K 5% 1/10W	
				R706	1-216-045-00	METAL CHIP 680 5% 1/10W	
				R707	1-216-073-00	METAL CHIP 10K 5% 1/10W	
				R708	1-216-097-91	RES,CHIP 100K 5% 1/10W	
				R709	1-216-081-00	METAL CHIP 22K 5% 1/10W	
				R710	1-216-073-00	METAL CHIP 10K 5% 1/10W	
				R711	1-216-025-91	RES,CHIP 100 5% 1/10W	

Ref. No.	Part No.	Description	Remark	Ref. No.	Part No.	Description	Remark
		< VARIABLE RESISTOR >				< CONNECTOR >	
RV401	1-241-764-11	RES, ADJ, CARBON 10K (VCO)		CN101	1-766-404-21	CONNECTOR, FFC (ZIF) 8P	
RV402	1-223-451-21	RES, VAR, CARBON 50K/50K (VOLUME)				< DIODE >	
		< SWITCH >		D101	8-719-941-04	DIODE SB007-03CP	
S401	1-572-552-11	SWITCH, SLIDE (NEWS/MUSIC)		D102	8-719-941-04	DIODE SB007-03CP	
S402	1-554-371-51	SWITCH, TACT (RESET)		D103	8-719-941-04	DIODE SB007-03CP	
		< TRANSFORMER >		D104	8-719-988-62	DIODE 1SS355	
T401	1-404-674-11	TRANSFORMER, IF (FM MIX)				< IC >	
T601	1-449-138-11	TRANSFORMER, DC-DC CONVERTER		IC101	8-759-539-32	IC MSM66587-102TS-K	
		< VIBRATOR >		IC102	8-759-249-34	IC S-80719SN-DG	
X501	1-567-769-11	VIBRATOR, CRYSTAL (75kHz)		IC103	8-759-368-42	IC RH5RH363B-T1	
*****				IC104	8-759-287-47	IC S-80728SN-DR-S	
		< CAPACITOR >		IC105	8-759-495-14	IC AT25160N-10SC2.7T2.5	
*	A-3663-105-A	MICOM BOARD, COMPLETE		IC201	8-759-433-87	IC SN74LV573PW-E20	
		*****		IC202	8-759-447-82	IC M5M51008BVP-15VLLTT4	
		< COIL >		IC203	8-759-539-33	IC MSM531031B-82TS-K	
C102	1-107-811-11	TANTAL. CHIP 47uF	20% 4V	IC204	8-759-539-31	IC MSM9553GS-2K	
C103	1-163-038-91	CERAMIC CHIP 0.1uF	25V	IC301	8-759-539-34	IC MSM69231-GS-2K	
C104	1-163-038-91	CERAMIC CHIP 0.1uF	25V			< TRANSISTOR >	
C105	1-126-204-11	ELECT CHIP 47uF	20% 16V	L101	1-411-621-21	INDUCTOR 120uH	
C106	1-125-486-11	DOUBLE LAYERS 0.22F	5.5V	L201	1-412-002-31	CHIP INDUCTOR 4.7uH	
C107	1-115-156-11	CERAMIC CHIP 1uF	10V			< RESISTOR >	
C108	1-163-038-91	CERAMIC CHIP 0.1uF	25V	R101	1-216-845-11	METAL CHIP 100K 5% 1/16W	
C109	1-163-038-91	CERAMIC CHIP 0.1uF	25V	R102	1-216-845-11	METAL CHIP 100K 5% 1/16W	
C111	1-115-156-11	CERAMIC CHIP 1uF	10V	R111	1-216-797-11	METAL CHIP 10 5% 1/16W	
C112	1-164-156-11	CERAMIC CHIP 0.1uF	25V	R112	1-216-821-11	METAL CHIP 1K 5% 1/16W	
C113	1-162-919-11	CERAMIC CHIP 22PF	5% 50V	R113	1-216-825-11	METAL CHIP 2.2K 5% 1/16W	
C114	1-162-918-11	CERAMIC CHIP 18PF	5% 50V	R114	1-216-821-11	METAL CHIP 1K 5% 1/16W	
C115	1-162-917-11	CERAMIC CHIP 15PF	5% 50V	R115	1-216-845-11	METAL CHIP 100K 5% 1/16W	
C116	1-164-156-11	CERAMIC CHIP 0.1uF	25V	R116	1-216-845-11	METAL CHIP 100K 5% 1/16W	
C117	1-164-156-11	CERAMIC CHIP 0.1uF	25V	R117	1-216-845-11	METAL CHIP 100K 5% 1/16W	
C201	1-163-038-91	CERAMIC CHIP 0.1uF	25V	R118	1-216-845-11	METAL CHIP 100K 5% 1/16W	
C202	1-135-201-11	TANTALUM CHIP 10uF	20% 4V	R119	1-216-845-11	METAL CHIP 100K 5% 1/16W	
C203	1-135-180-21	TANTALUM CHIP 3.3uF	20% 6.3V	R120	1-216-821-11	METAL CHIP 1K 5% 1/16W	
C204	1-164-362-11	CERAMIC CHIP 470PF	5% 50V	R121	1-216-821-11	METAL CHIP 1K 5% 1/16W	
C205	1-164-346-11	CERAMIC CHIP 1uF	16V	R122	1-216-821-11	METAL CHIP 1K 5% 1/16W	
C206	1-162-919-11	CERAMIC CHIP 22PF	5% 50V	R123	1-216-821-11	METAL CHIP 1K 5% 1/16W	
C207	1-162-919-11	CERAMIC CHIP 22PF	5% 50V	R124	1-216-845-11	METAL CHIP 100K 5% 1/16W	
C208	1-163-038-91	CERAMIC CHIP 0.1uF	25V	R125	1-216-845-11	METAL CHIP 100K 5% 1/16W	
C209	1-135-201-11	TANTALUM CHIP 10uF	20% 4V	R126	1-216-845-11	METAL CHIP 100K 5% 1/16W	
C220	1-163-038-91	CERAMIC CHIP 0.1uF	25V	R127	1-216-845-11	METAL CHIP 100K 5% 1/16W	
C221	1-164-346-11	CERAMIC CHIP 1uF	16V	R128	1-216-845-11	METAL CHIP 100K 5% 1/16W	
C222	1-162-957-11	CERAMIC CHIP 220PF	5% 50V				
C223	1-162-957-11	CERAMIC CHIP 220PF	5% 50V				
C224	1-163-038-91	CERAMIC CHIP 0.1uF	25V				
C225	1-163-038-91	CERAMIC CHIP 0.1uF	25V				
C226	1-163-038-91	CERAMIC CHIP 0.1uF	25V				
C301	1-135-201-11	TANTALUM CHIP 10uF	20% 4V				
C302	1-162-919-11	CERAMIC CHIP 22PF	5% 50V				
C303	1-162-919-11	CERAMIC CHIP 22PF	5% 50V				
C304	1-162-915-11	CERAMIC CHIP 10PF	0.5PF 50V				

## MICOM

Ref. No.	Part No.	Description	Remark	Ref. No.	Part No.	Description	Remark
R129	1-216-845-11	METAL CHIP	100K 5% 1/16W	R187	1-216-821-11	METAL CHIP	1K 5% 1/16W
R130	1-216-845-11	METAL CHIP	100K 5% 1/16W	R188	1-216-821-11	METAL CHIP	1K 5% 1/16W
R131	1-216-845-11	METAL CHIP	100K 5% 1/16W	R189	1-216-845-11	METAL CHIP	100K 5% 1/16W
R132	1-216-845-11	METAL CHIP	100K 5% 1/16W	R190	1-216-845-11	METAL CHIP	100K 5% 1/16W
R133	1-216-845-11	METAL CHIP	100K 5% 1/16W	R193	1-216-845-11	METAL CHIP	100K 5% 1/16W
R134	1-216-809-11	METAL CHIP	100 5% 1/16W	R201	1-216-797-11	METAL CHIP	10 5% 1/16W
R136	1-216-821-11	METAL CHIP	1K 5% 1/16W	R202	1-216-821-11	METAL CHIP	1K 5% 1/16W
R137	1-216-821-11	METAL CHIP	1K 5% 1/16W	R203	1-216-821-11	METAL CHIP	1K 5% 1/16W
R138	1-216-845-11	METAL CHIP	100K 5% 1/16W	R204	1-216-821-11	METAL CHIP	1K 5% 1/16W
R139	1-216-845-11	METAL CHIP	100K 5% 1/16W	R205	1-216-821-11	METAL CHIP	1K 5% 1/16W
R140	1-216-821-11	METAL CHIP	1K 5% 1/16W	R206	1-216-821-11	METAL CHIP	1K 5% 1/16W
R141	1-216-821-11	METAL CHIP	1K 5% 1/16W	R207	1-216-821-11	METAL CHIP	1K 5% 1/16W
R142	1-216-821-11	METAL CHIP	1K 5% 1/16W	R208	1-216-821-11	METAL CHIP	1K 5% 1/16W
R143	1-216-821-11	METAL CHIP	1K 5% 1/16W	R209	1-216-821-11	METAL CHIP	1K 5% 1/16W
R144	1-216-821-11	METAL CHIP	1K 5% 1/16W	R210	1-216-809-11	METAL CHIP	100 5% 1/16W
R145	1-216-821-11	METAL CHIP	1K 5% 1/16W	R211	1-216-797-11	METAL CHIP	10 5% 1/16W
R146	1-216-821-11	METAL CHIP	1K 5% 1/16W	R220	1-216-797-11	METAL CHIP	10 5% 1/16W
R147	1-216-821-11	METAL CHIP	1K 5% 1/16W	R221	1-216-797-11	METAL CHIP	10 5% 1/16W
R148	1-216-821-11	METAL CHIP	1K 5% 1/16W	R222	1-216-797-11	METAL CHIP	10 5% 1/16W
R149	1-216-821-11	METAL CHIP	1K 5% 1/16W	R223	1-216-797-11	METAL CHIP	10 5% 1/16W
R150	1-216-821-11	METAL CHIP	1K 5% 1/16W	R224	1-216-841-11	METAL CHIP	47K 5% 1/16W
R151	1-216-821-11	METAL CHIP	1K 5% 1/16W	R225	1-216-845-11	METAL CHIP	100K 5% 1/16W
R152	1-216-821-11	METAL CHIP	1K 5% 1/16W	R226	1-216-797-11	METAL CHIP	10 5% 1/16W
R153	1-216-821-11	METAL CHIP	1K 5% 1/16W	R301	1-216-797-11	METAL CHIP	10 5% 1/16W
R154	1-216-821-11	METAL CHIP	1K 5% 1/16W	R302	1-216-845-11	METAL CHIP	100K 5% 1/16W
R155	1-216-821-11	METAL CHIP	1K 5% 1/16W	R303	1-216-809-11	METAL CHIP	100 5% 1/16W
R156	1-216-821-11	METAL CHIP	1K 5% 1/16W	R304	1-216-821-11	METAL CHIP	1K 5% 1/16W
R157	1-216-821-11	METAL CHIP	1K 5% 1/16W	R305	1-216-821-11	METAL CHIP	1K 5% 1/16W
R158	1-216-821-11	METAL CHIP	1K 5% 1/16W	R306	1-216-821-11	METAL CHIP	1K 5% 1/16W
R159	1-216-821-11	METAL CHIP	1K 5% 1/16W			< COMPOSITION CIRCUIT BLOCK >	
R160	1-216-845-11	METAL CHIP	100K 5% 1/16W	RB301	1-236-904-11	NETWORK RESISTOR (CHIP) 1.0K	
R161	1-216-845-11	METAL CHIP	100K 5% 1/16W			< VIBRATOR >	
R162	1-216-845-11	METAL CHIP	100K 5% 1/16W	X101	1-760-880-21	VIBRATOR, CERAMIC (4.9152MHz)	
R163	1-216-821-11	METAL CHIP	1K 5% 1/16W	X201	1-760-639-11	VIBRATOR, CRYSTAL (8.192MHz)	
R164	1-216-821-11	METAL CHIP	1K 5% 1/16W	X301	1-760-880-21	VIBRATOR, CERAMIC (4.9152MHz)	
R165	1-216-821-11	METAL CHIP	1K 5% 1/16W	*****			
R166	1-216-821-11	METAL CHIP	1K 5% 1/16W	MISCELLANEOUS			
R167	1-216-821-11	METAL CHIP	1K 5% 1/16W	*****			
R168	1-216-821-11	METAL CHIP	1K 5% 1/16W	3	1-762-590-21	SWITCH, RUBBER KEY (MENU)	
R169	1-216-821-11	METAL CHIP	1K 5% 1/16W	4	1-762-591-21	SWITCH, RUBBER KEY (POWER)	
R170	1-216-821-11	METAL CHIP	1K 5% 1/16W	LCD1	1-801-152-11	LCD MODULE	
R171	1-216-821-11	METAL CHIP	1K 5% 1/16W	*****			
R172	1-216-821-11	METAL CHIP	1K 5% 1/16W	ACCESSORIES & PACKING MATERIALS			
R173	1-216-821-11	METAL CHIP	1K 5% 1/16W	*****			
R174	1-216-821-11	METAL CHIP	1K 5% 1/16W	3-864-117-11	MANUAL, INSTRUCTION (ENGLISH, FRENCH, GERMAN)		
R175	1-216-845-11	METAL CHIP	100K 5% 1/16W	8-953-538-90	HEADPHONE MDR-E741//K2 SET		
R176	1-216-845-11	METAL CHIP	100K 5% 1/16W				
R177	1-216-821-11	METAL CHIP	1K 5% 1/16W				
R178	1-216-821-11	METAL CHIP	1K 5% 1/16W				
R179	1-216-845-11	METAL CHIP	100K 5% 1/16W				
R180	1-216-821-11	METAL CHIP	1K 5% 1/16W				
R181	1-216-821-11	METAL CHIP	1K 5% 1/16W				
R182	1-216-821-11	METAL CHIP	1K 5% 1/16W				
R183	1-216-821-11	METAL CHIP	1K 5% 1/16W				
R184	1-216-821-11	METAL CHIP	1K 5% 1/16W				
R185	1-216-821-11	METAL CHIP	1K 5% 1/16W				
R186	1-216-821-11	METAL CHIP	1K 5% 1/16W				